

## **HARDNESS – TYPES AND APPLICATION**

**Anna Bouzekova - Penkova**

*Space Research and Technology Institute – Bulgarian Academy of Sciences*  
*email: a\_bouzekova@abv.bg*

**Keywords:** *Hardness, hardness tests, metals, alloys, hardness testers*

**Abstract:** *This article presents a brief review on the types of hardness and various methods for measuring it, namely through Brinell, Rockwell, Vickers, Knoop and others. The factors influencing the choice of hardness measurement methods and applications for hardness measurement on different materials are considered.*

## **ТВЪРДОСТ – ВИДОВЕ И ПРИЛОЖЕНИЕ**

**Анна Бузекова - Пенкова**

*Институт за космически изследвания и технологии – Българска академия на науките*  
*email: a\_bouzekova@abv.bg*

**Ключови думи:** *Твърдост, тестове за твърдост, метали, сплави, твърдомери*

**Резюме:** *В тази статия се прави преглед на видовете твърдост и на различните методи за измерване на твърдостта, а именно Бринел, Рокуел, Викерс, Кнуп и други. Разгледани са факторите, които оказват влияние върху избора на методите за измерване на твърдостта и приложенията за измерването на твърдост върху различни материали.*

### **Introduction**

Each engineering and design activity is associated with the calculation and sizing of mechanically loaded parts and structures operating in various conditions both on Earth and in space. Therefore, the main mechanical characteristic that determines the behavior and suitability of any material is hardness. It is defined as the property of a material to withstand a uniformly and gradually increasing load of a certain size applied to it, causing a compressive stress on its surface. The test is fast, relatively easy, and can be applied to the finished product without damaging or destroying the material [1-10].

Most often, the hardness of substances is measured in special units - kgf/mm<sup>2</sup> (kilogram-force per square millimeter of area). It is evaluated by the so-called hardness number, which characterizes the stability of the material. The size of the numbers is determined according to the measurement principle, denoted by the Latin letters HB (Brinell method), HV (Vickers method), HR (Rockwell method) [2, 3, 4, 7, 10].

There are three main types of hardness:

- Surface (determined by the ratio of the size of the load to the surface of the imprint);
- Projection (the ratio of the load to the projection area of the imprint);
- Volume (ratio of load to imprint volume).

In addition, the hardness of physical bodies is measured in four ranges:

- Nanohardness. The nano range only controls the penetration depth of the indenter, which should be less than 0.2 microns.
- Microhardness. The micro range adjusts the load value of the indenter up to 2 N (1 - 200 g) and the penetration depth of the indenter is more than 0.2 μm.
- Hardness at low loads. The macro range regulates the amount of load on the indenter from 200 g to 5 kgf.

- Macrohardness. The macro range adjusts the load on the indenter from 2 to 30 kN [2, 4, 10].

### Types of hardness measurement methods

According to the method of applying the load, hardness testing methods are divided into static and dynamic.

**Static methods:** In static methods, the degree of penetration of the indenter into the material is assessed (dent or scratch method). In this case, the hardness value is equal to the load relative to the indentation surface or is inversely proportional to the indentation depth at a given fixed load. The imprint is usually made with a hardened steel sphere (Brinell and Rockwell methods), a diamond cone (Rockwell method) or a diamond pyramid (Vickers method, micro hardness measurement). Since a steel sphere and a diamond cone are used to determine the hardness by the Rockwell method, additional notations are often introduced - V (ball) and A (cone). Using special tables or diagrams, we can recalculate the hardness numbers. The Rockwell hardness number can be converted to a Brinell hardness number.

#### • Hardness determination by the Brinell method (HB)

The hardness determined by this method is denoted HB, where H - hardness (from English - hardness), B - Brinell (the method is named after the Swedish engineer J. A. Brinell).

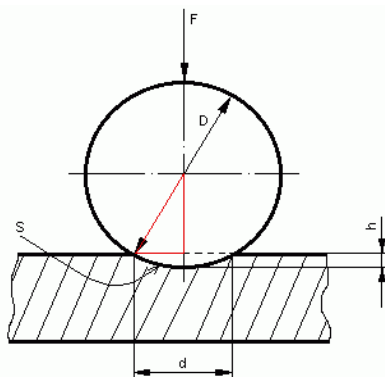

Fig. 1. Brinell hardness test

The test temperature must be within the range of  $20 \pm 10$  °C. The measurement is carried out by inserting a hardened steel ball of diameter  $D$  into the test piece under a load  $F$  applied for a specified time. After removing the action of the load, the diameter  $d$  of the imprint on the surface is measured. The Brinell hardness number is defined as the ratio between the applied load and the face of the spherical imprint [1].

$$(1) \quad HB = \frac{F}{S} = \frac{F}{\pi D h} ;$$

$$(2) \quad HB = \frac{2F}{\pi D (D - \sqrt{D^2 - d^2})} .$$

Where:  $F$  - load in N (kgf);  $S$  is the area of the recess in  $\text{mm}^2$ ;  $h$  is the depth of penetration (of the imprint);  $D$  is the diameter of the steel ball in mm;  $d$  - imprint diameter, mm.

The values of the diameter of the sphere  $D$  and the force  $F$  are chosen according to the following dependence:

-  $D$  is selected according to the sample thickness  $\delta$  and can be from 2 to 10 mm. The imprint on the sample must not exceed 0, 25 to 0,6.  $D$  or  $d =$  (from 0.25 to 0.6)  $\cdot D$ .

-  $F$  is chosen according to the type of material and must be proportional to the square of the ball diameter and is 43, 36, 29, 7, and 1.54 kN (3000, 750 and 187.5 kg, respectively). It works for a certain time depending on the material; for example, for ferrous metals 10 or 30 seconds, for non-ferrous metals 30 seconds and for bearing alloys it is 60 seconds.

The hardness by this method is recorded in units without dimension before its designation, which may be: HBS when using a steel ball for metals with a hardness of less than 450 units; HBW - when using a hard alloy ball with a hardness from 450 to 650 units [1-4].

#### • Determination of hardness by the Rockwell method (HR)

The hardness determined by this method is designated HR, where H is hardness (from English - hardness), R - according to Rockwell (the method is named after the American metallurgist S. Rockwell who developed this method).

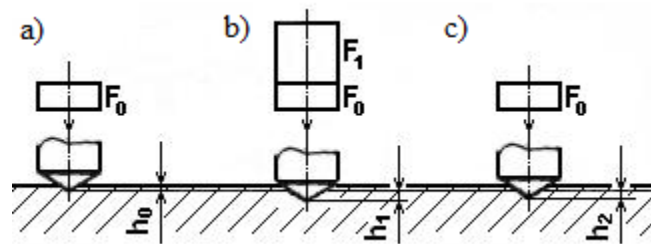

Fig. 2. Rockwell hardness test

When measuring hardness by this method, the penetrating body is a diamond cone (for hard materials and hardened steels) with a peak angle of  $120^\circ \pm 30^\circ$  (Fig. 2) and a spherical curvature at the tip with a radius of 0.2 mm. For testing softer materials, a hardened steel sphere with a diameter of 1.588 mm is used as an indenter. Rockwell hardness is determined by the depth of insertion of the indenter (cone or sphere) into the material under study. The measurement is performed using an indicator clock. It detects the penetration of the indenter into the material. For the numerical characteristic of the hardness, a conditional scale with numbers is introduced, plotted in the reverse order of the movement of the arrow. The sinking of the tip to a depth of 0.002 mm corresponds to a division of the hardness reading scale. One full turn of the arrow corresponds to a penetration of 0.2 mm. With the assumed direction of movement of the arrow, the greater the sinking, the lower the value obtained for the hardness.

The loading is performed in the following sequence. The diamond cone (or sphere) is pressed against the surface of the object with a force  $F_0$  (preload), as a result of which it sinks to a certain depth (Fig. 2a). This position is taken as the starting point, the scale of the indicator with which the penetration is measured is adjusted so that its arrow under the action of the preload  $F_0$  shows 0 (100). Then to the force  $F_0$  is added another, larger force  $F_1$  - the main load (Fig. 2b). Under the action of the total load  $F = F_0 + F_1$  the cone penetrates to a greater depth. At this moment, the entire device is under stress and undergoes elastic deformations, which are also read by the indicator. Consequently, its arrow shows the sum of the depth of sinking under the action of the second (main) load  $F_1$  and the deformations of the instrument. The main load  $F_1$  is removed (Fig. 2c), as a result of which only the preliminary load  $F_0$  remains on the cone. In this case, the hand of the indicator clock returns as much as the elastic deformations of the instrument and the test material caused by the action of the second load  $F_1$ .

Depending on the type of nozzle, the load is different. For a cone, a preload  $F_0 = 98.1$  N (10 kgf) and a main load  $F_1 = 1342$  N (140 kgf) are used, i.e. the total load is  $F = 1470$  N (150 kgf). The reading is done on the scale "C" of the device ("C" - cone-cone), which has 100 divisions. For a sphere, the same preload  $F_0$  and main load  $F_1 = 882$  N (90 kgf) are introduced, i.e. the total load is  $F = 981$  N (100 kgf). The test is performed in the same way, but a scale "B" ("B" - Ball-sphere) is used, which has 130 divisions. It is applied for hardness from 60 HB to 240 HB. Reported hardness is between 25 and 100 HRB.

Under the conditions adopted in this way, the Rockwell hardness, expressed in arbitrary units, is associated with the sinking of the indenter by the following formulas:

$$(3) \quad \text{HRC} = 100 - \frac{h - h_0}{0,002} \quad \text{- for scale "C";}$$

$$(4) \quad \text{HRC} = 130 - \frac{h - h_0}{0,002} \quad \text{- for scale "B".}$$

The "A" scale is sometimes used. It operates with a diamond cone and a total load of  $F = 588$  N (60 kgf) at the same preload  $F_0$ . This scale is used for Vickers hardness above 700 HV. Hardness scales from 70 HRA to 86.5 HRA can be reported. On the indicator, the two scales ("A" and "C") coincide and are marked with the letter "C" [1-4].

• **Determination of hardness by the Vickers method (HV)**

The hardness determined by this method is denoted HV, where H is hardness (from English - hardness), V - Vickers (on behalf of the English military industrial concern Vickers Limited).

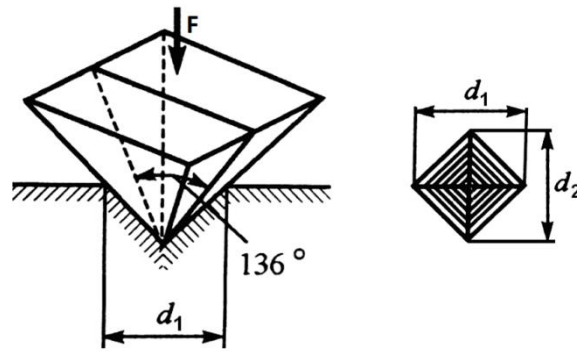

Fig. 3. Vickers hardness test

This method is universal. The hardness test is carried out in the same way as in the Brinell method, but for the penetrating body, a tetrahedral diamond pyramid with an apex angle of  $136^\circ \pm 20^\circ$  is used, pressed against the surface (Fig. 3). Hardness is calculated as the ratio of the load applied to the pyramid to the area of the imprint (in addition, the area of the imprint is taken as the area of a part of the surface of the pyramid, and not as the area of the rhombus).

$$(5) \quad HV = \frac{F}{S}, \text{MPa}(\text{kgf}/\text{mm}^2).$$

To calculate the area of an imprint, its diagonals are measured with an accuracy of 0.001 mm and their arithmetic mean is determined.

$$(6) \quad S = \frac{d^2}{2\cos 22^\circ} = \frac{d^2}{1,8544} = \text{mm}^2,$$

$$(7) \quad HV = \frac{F}{S} = \frac{1,8544F}{d^2}, \text{MPa}(\text{kgf}/\text{mm}^2),$$

where F is in kgf and S is  $\text{mm}^2$ .

The diagonals of the imprint are measured with a microscope attached to the instrument. Determination of hardness is carried out according to tables, as in the Brinell method [1-4].

• **Determination of hardness by the Knoop method (HK)**

The hardness determined by this method is denoted HK, where H - hardness (from English - hardness), K - Knoop (Knoop). The Knoop method is sometimes used to more accurately measure the hardness of very thin layers. The method is an improved modern version of the Vickers method [9]. The diamond tip is pyramid-shaped with a diamond-shaped cross-section. The imprint has diagonals of different lengths, one of which is 7 times longer than the other. Imprint depth is 1/30 of the length of the large diagonal. The resulting hardness, determined by measuring the large diagonal, is called Knoop hardness [5-8].

**Dynamic methods:** Dynamic methods estimate the energy loss when interacting with the material [1]. The measure of hardness is the height of the bounce of a steel ball from the surface of the studied metal (Poldi's method, Shore's method) or the decay time of the oscillation of the pendulum whose support is the studied metal (Kuznetsov - Herbert - Rebinder method).

• **Determination of hardness by the Poldi method (HP)**

The hardness determined by this method is denoted by HP, where H - hardness (from English - hardness), P - Poldi. The hardness test is performed with a steel sphere which strikes both the test metal and the reference sample (Fig. 4a), the hardness of which is known. The comparison of the obtained imprints on the standard and the tested material allows determining the hardness of the latter. The hardness of the test material is determined by the following formula:

$$(8) \quad HP = HB = \frac{HB_0(D - \sqrt{D^2 - d_0^2})}{D - \sqrt{D^2 - d^2}};$$

where D is the diameter of the steel ball; d is the diameter of the recess on the surface of the test material;  $d_0$  - diameter of the reference sample [2,8].

• **Determination of hardness by the Shore method (HSx)**

The hardness determined by this method is denoted HSx, where H - hardness (from English - hardness), S - Shore (on behalf of Albert Shore), x - scale type.

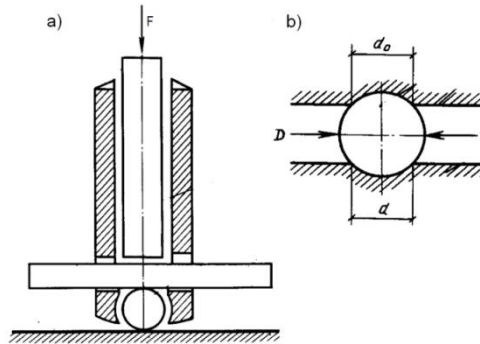

Fig. 4. Poldi hardness test:  
a) Poldi percussion device, b) imprint made of steel sphere

The measurement is based on the free fall of the diamond indicator onto the test surface from a certain height. For testing, special equipment is used to accurately record the height of the rebound. The mass of the used impactor with a diamond tip is 36 grams. This method uses two types of indentation, shown in Figure 5 [2,8].

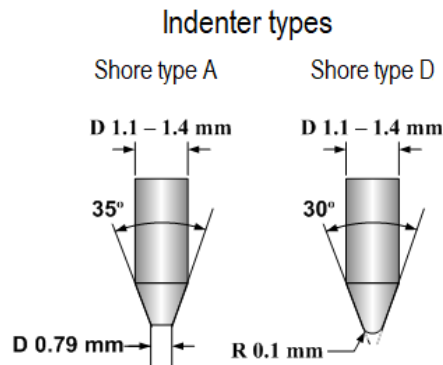

Fig. 5. Shore hardness test: a) indenter type A (for soft materials), b) indenter type D (for hard materials)

• **Determination of hardness by the Kuznetsov - Herbert - Rebinder method**

The hardness is determined by the decay time of the oscillations of the pendulum, which is supported by the metal under study [2].

**Application of the methods and conclusion**

The choice of hardness testing method depends on several factors: the level of hardness (and scale limitations), sample thickness, size and shape of the workpiece, flatness and condition of the sample surface, location of the dent, productivity, and type of tested material, measurement tasks, conditions for its implementation, available equipment and other factors. It is important to select a suitable hardness scale for good repeatability of test results. The choice of a suitable hardness scale depends on the expected hardness range of the material under test (which can be determined from its overall composition and processing history or some trial and error) and the type of indenter. Sometimes, however, the scale has to be defined and chosen to suit a given set of circumstances. In general, the scale using a diamond indenter (Rockwell and Vickers) is used to test hardened steels and alloys; while ball indents (Brinell and Rockwell) are used for more ductile materials.

Depending on the scale used in the Shore hardness testers, they are used to measure:

- Shore A - measuring the hardness of rubber, elastomers, neoprene, silicone, vinyl, soft plastics, felt, leather and other similar materials;
- Shore D - measuring the hardness of plastics, PVC, epoxy resins, plexiglass, etc.;
- Shore A0 - measuring the hardness of foam, sponges, etc.

Materials are the foundation of all human activity. Without improving their mechanical properties, including hardness and its measurements, the development of mankind (as well as aerospace and related industries) would be unthinkable. According to the obtained value of hardness, preliminary

conclusions can be made for other mechanical properties of the metal (alloy), as most of the properties of metals and alloys are determined by the same indicator - their structure and their heat treatment; the hardness measurement makes it possible to assess the presence (or absence) of hardened surfaces in parts as a result of different types of heat treatment of alloys associated with a change in the cross-sectional structure of the part [1, 6, 10, 11]. As an example: it is possible to create the tensile curve of the materials by hardness measurement results on the application of a method of finite element. In the future, due to the lack of unified world standards of hardness, an analysis of the compliance of our and foreign standards for methods of measuring hardness can be carried out.

In our department in SRTI-BAS was synthesized a new Al-based alloy, namely aluminum alloy 7075 strengthened with nanoparticles of diamond powder and Tungsten.

Several samples of the so modified, with nanodiamonds and TungstenW, aluminium alloy 7075 (AA7075+W+ND), prepared in our department, were a part of the DP-PM module of the international outer space experiment "Obstanovka" (carried out in the Russian sector of the International Space Station).

The aim of this international space experiment was to investigate influence of the outer space environment on the properties of the alloy (AA7075+W+ND) for 28 months. After this exposure to the outer space influence, the samples were returned to the Earth for future research. Today the comparative analysis of the properties of the samples, including the hardness measurements, (One of the samples was stored in terrestrial conditions, and the other sample was mounted on the outside of the International

Space station for the same period) has already been done [12-14]. They need to be checked to see if the data has changed over time.

### References:

1. Geller, Yu. A., A. G. Rakhshadt. Materials Science, Metallurgiya [in Russian], Moscow, 1975.
2. Metals Handbook, 9<sup>th</sup> ed., Mechanical Testing, Vol. 8, 1990.
3. Dieter, G., Mechanical Metallurgy, S1 ed., Mc Graw Hill, 1986.
4. Dowling, Mechanical Behavior of Materials, Prentice Hall, 1993.
5. Dumanskiy, I. O., V. M. Aleksandrov, V. L. Sytin, Measurements of hardness of metals and alloys Arkhangel'sk: SAFU, 2013 [in Russian].
6. Anikin, A. A., S. B. Venig, A. G Zhukov, S. B. Stetsyura, K. Yu. Chernenkov. Metallurgy, Saratov, 2015 [in Russian].
7. Herrmann, K., et al. (ed.). Hardness testing: principles and applications. ASM International, 2011.
8. Vasilevich, Yu. V., Ye. Yu. Neumerzhitskaya, A. M. YAznevich, N. N. Kuzmenko. Measurement of hardness of metals, Minsk, 2010 [in Russian].
9. Brinell, J. A., II Cong. Int. Méthodes d' Essai (Brief on steel ball tests) (Paris), 1900 [in French].
10. Tabor, D.. The Hardness of Metals, Clarendon Press, Oxford, 1951.
11. Miteva, A.. On the microstructure and strengthening of aluminium and aluminium alloys, Tribological Journal BULTRIB, BULTRIB '12, Sofia 2013, 3, pp. 367–370.
12. Bouzekova – Penkova, A.. Investigations of the mechanical properties of a dispersion-reinforced aluminum alloy intended for outer space, SES 2013, Sofia, Bulgaria, 2013, pp. 492–496.
13. Bouzekova – Penkova, A., K. Grigorov, M. Datcheva, C. A. Cunha. Influence of the outer space on Nanohardness properties of Al- based alloy, C. R. Acad. Bulg. Sci., 69 (10), 2016, pp. 1351–1354.
14. Bouzekova-Penkova, A., M. Datcheva, R. Iankov. Mechanical properties of the enhanced with nanodiamond and tungsten strengthened aluminium alloy being exposed in the Outer space, International Journal "NDT Days", Vol. II (4), 2019, pp. 396–401.