

NEW PLANT SHOOT ENVIRONMENT MONITORING SYSTEM FOR THIRD GENERATION SVET SPACE GREENHOUSE

Yordan Naydenov, Slaveyko Neychev, Iliana Ilieva

Space Research Institute – Bulgarian Academy of Sciences
e-mail: yordan.naydenov@space.bas.bg

Keywords: Monitoring System, Sensors, Adaptive Control, SVET Space Greenhouse

Abstract: A new sensor subsystem for leaf zone environment parameters measurement was developed in accordance with the recently proposed concept for adaptive environmental control of the plant growth conditions. Sensors of high quality, both commercial and proprietary, are used to obtain a fine performance. Data acquisition process is realized by a microcomputer system and appropriate software is built up. Two one-month experiments were carried out to test the system functioning during long-term operating conditions and at different environmental parameter values fluctuations. The last was achieved by a double plant chamber volume reduction. Results obtained show that the new plant shoot zone environment monitoring system is reliable and work properly. As a next step, the system would be developed to collect plant physiological status data and to control the environmental parameters in dynamics through the actuating mechanisms of the greenhouse in order to provide most favourable conditions for plant vegetation as defined by the new concept.

Introduction

The SVET Space Greenhouse (SG) has maintained successfully different plant growth and development experiments for a decade onboard the MIR Orbital Space Station with a total continuous operation time of almost two years. Eight experiments carried out in the period 1990-2000 within five international scientific programs and two SG modifications showed that higher plants can grow and reproduce in microgravity environment [1,2]. As a result, second generation space-produced seeds were obtained for the first time ever [3]. All these ended up long standing efforts to cultivate and reproduce plants in Space in order to include them as a part of future Biological Life Support Systems (BLSS) for long-term manned space missions [4].

The success of the experiments and the fundamental results obtained were due to the automation of the SVET SG. The experience gained through the years with the first in the world automatic plant growth facility has helped for further development of the instrumentation and biotechnology underlying the SVET design and has lead to a concept for adaptive control of the environmental parameters [5]. For this to be realized, a measurement process of both environmental and plant physiological parameters must be established. Plant root environment has been monitored since SVET was constructed in the late 1980s. Recently, we build up a second monitoring system to measure some plant shoot environment parameters and these are: (1) light intensity; (2) air temperature; (3) air humidity; (4) air flow velocity and (5) air pressure. The measurement of the rest of the parameters needed for an evaluation of the physiological status of the plants cultivated is a matter of future expansions of the system (Fig. 1).

All sensors used, except the air pressure one, are placed in the Plant Chamber (PCh) of SVET. They are grouped as a battery mounted on a rack. The rack is moved dynamically during the plant growth so the sensor battery to be always located at the top of the plant canopy. At present, only one sensor for each type of parameter measured is employed by the system.

Materials and methods

Sensors

The new plant shoot environment parameters measurement system consists of five sensors implemented as four separate physical entities. This is so because the relative air humidity is dependant of the air temperature and it is preferable to use combined humidity and temperature sensing to achieve high accuracy measurement and by reasons of compactness and reliability.

HIH-3602-C monolithic IC humidity sensor (Honeywell International Inc., Morris Township, NJ, USA) is used for temperature compensated Relative Humidity (RH) and Air Temperature (AT) measurements. The temperature sensor, a thin film platinum RTD element (Pt1000 resistor), is thermally connected with the RH sensor – a planar capacitor element. Both elements are integrated in the RH sensor package – a TO-5 can.

The sensor has fast response, high accuracy and stability. It is chemically resistant. The main performance specifications are: RH Accuracy – $\pm 2\%$ RH (0-100% RH non-condensing, 25°C); RH Repeatability – $\pm 0.5\%$ RH; RH Response Time – 50 sec in slowly moving air at 25°C; RH Stability – $\pm 1\%$ RH typical (at 50% RH in 5 years); Operating Humidity Range – 0 to 100% RH, non-condensing; Temperature Accuracy – $\pm 0.5^\circ\text{C}$ at 25°C; Operating Temperature Range – -40 to 85°C. A low value of the measuring current through the resistor is used to reduce the measurement error due to sensor self-heating.

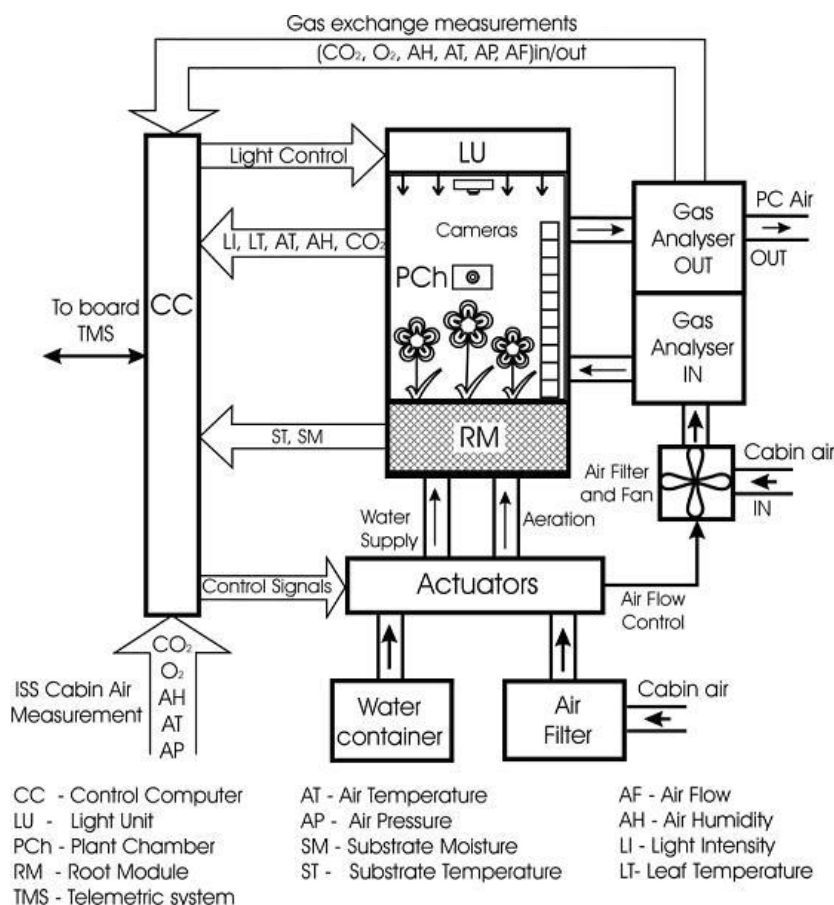

Fig. 1. Conceptual Block Diagram of the SVET-3 SG for the International Space Station (ISS).

BPW21R planar silicon PN photodiode (Vishay Semiconductor GmbH, Heilbronn, Germany) is used as Light Intensity (LI) sensor. It is hermetically sealed in TO-5 case, and has large radiant sensitive area ($A = 7.5 \text{ mm}^2$). The main optical characteristics are the following: Range of Spectral Bandwidth $\lambda_{0.5}$ from 420 to 675 nm; Wavelength of Peak Sensitivity $\lambda_p = 565 \text{ nm}$; Typical Sensitivity $S = 9 \text{ nA}\cdot\text{lx}^{-1}$; Angle of Half Sensitivity $\varphi = \pm 50^\circ$. In the future, the sensor will be replaced with PAR quantum one to measure photosynthetically active radiation.

The Air Flow Velocity (AFV) sensor is developed by Bulgarian electronic engineers (Bulgarian Author's Certificate No. 44174 / 1985). It consists of two miniature transistors which are in thermal contact with the air. The first transistor's temperature is equal to that of the ambient air and differs by 80°C from the temperature of the second one. The temperature difference between the transistors is kept always constant by the sensor electronics and the energy needed for that is proportional to the air flow velocity. The sensor characteristics are: compact size, linear measurement range from $2 \text{ cm}\cdot\text{s}^{-1}$ to $2 \text{ m}\cdot\text{s}^{-1}$ AFV, independence of the AFV measurement from the air temperature in a wide range of the latter.

The air pressure is measured by a piezoresistive absolute pressure sensor KPY10 (Siemens AG, Munich, Germany). Its measurement range is $0 \div 2 \text{ bar}$. The sensor is cased in TO-8 can. It is located outside the PCh and a connection with the plant shoot environment is established by a rubber flexible tube.

Data Acquisition System (DAS)

ME-Jekyll/ME-4610 (Meilhaus Electronic, Puchheim, Germany) multifunction data acquisition (DAQ) PC plug-in board is used to acquire data signals produced by the sensor sub-systems in the plant shoot zone. It consists of two sections – an analog-to-digital (A/D) and a digital input/output (I/O) one. The A/D section has 16 single ended input channels which are routed through a high impedance input stage to a 16-

bit 500 kHz A/D converter. The input voltage range is fixed to ± 10 V. The digital I/O section has 32 TTL-I/Os which are organized as four 8-bit bi-directional ports.

Additionally, there are 3 independent, free programmable 16-bit counters available on the board. They can be connected externally and a desired output signal with a variable duty cycle may be created, a process referred to as Pulse Width Modulation (PWM). The duty cycle can be set between 1-99% in 1% increments.

The DAQ board is plugged into a PCI-bus slot on the Control Computer (CC) of SVET-3 (Fig. 2).

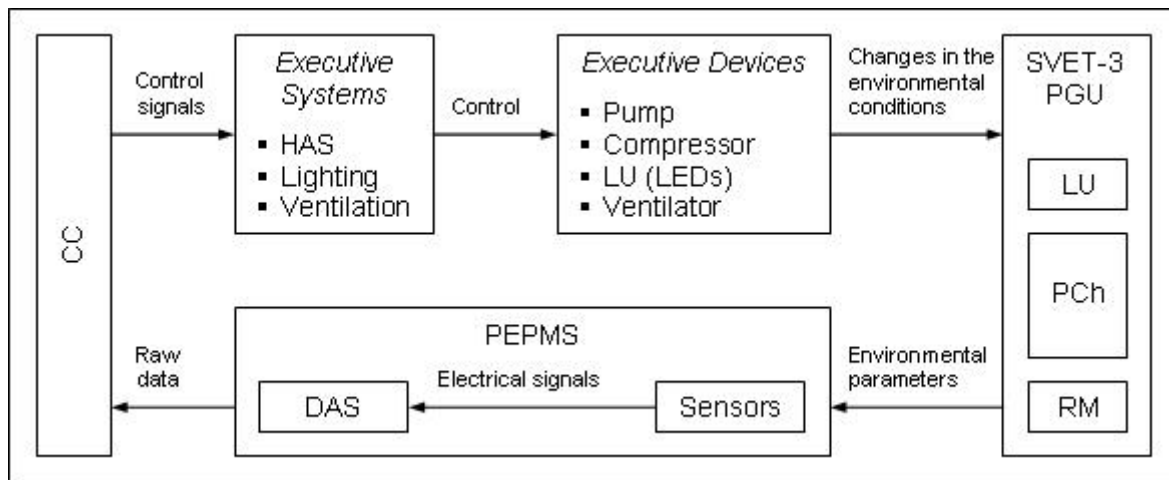

CC – Control Computer; HAS – Hydro-Aero System; PGU – Plant Growth Unit; LU – Light Unit; PCh – Plant Chamber; RM – Root Module; PEPMS – Plant Environment Parameters Measurement System; DAS – Data Acquisition System.

Fig. 2. Block diagram of the data acquisition and control systems of the SVET-3 SG.

DAS Software

Proprietary software was built up to organize the acquisition process, to convert the electrical signals produced by the sensors in real environmental parameters' values and to display the plant shoot zone environmental conditions data in a convenient manner.

One single data acquisition event consists of five thousand reads of sensor data within a period of a half of second. This means that each of the five parameters scanned by the monitoring system is measured 1000 times for 0.5 sec. After that the CC calculates the average value for each environmental parameter.

The time interval between two consecutive data acquisitions can be changed from 1 min to 24 hours by a resolution of 1 min, i.e. data acquisition frequency can be varied from 1440 to 1 data acquisition event per day. Additionally, the SG operator can trigger an acquisition event at any time he wants to see the status of the environment within the PCh.

Data Representation and Storage

Environmental parameters observed by the monitoring system are displayed in a six-column table in the program window space. The first column indicates the time in which a data acquisition event is started and the rest are reserved for the measured values of light intensity, temperature, relative humidity, air pressure and air flow velocity, respectively. Data acquisitions are displayed in real time consecutively in the table rows according to the acquisition frequency set by the experimenter / SG operator. The table content is cleared at the beginning of a new calendar day and the data acquisition process gradually refills the table.

Each data row is written at the end of a special data storage text file after it has been visualized on the screen. These files are generated automatically by the program for each calendar day. File names are in mm/dd/yy format. The information stored in the files is structured in the same table-oriented manner as it is displayed.

Results

To test the system functionality and reliability two one-month test experiments were conducted. These were plant vegetations carried out in an operating regime (automatic control mode) of the SVET SG, which was working in an air-conditioned laboratory. The alteration of the range at which the environmental parameters' values varied was performed by a double volume reduction of the PCh.

The results obtained for the leaf zone environment parameters' dynamics during the plant growth experiments are summarized and represented graphically as so called parametrograms of the vegetation process (Fig. 3a, b).

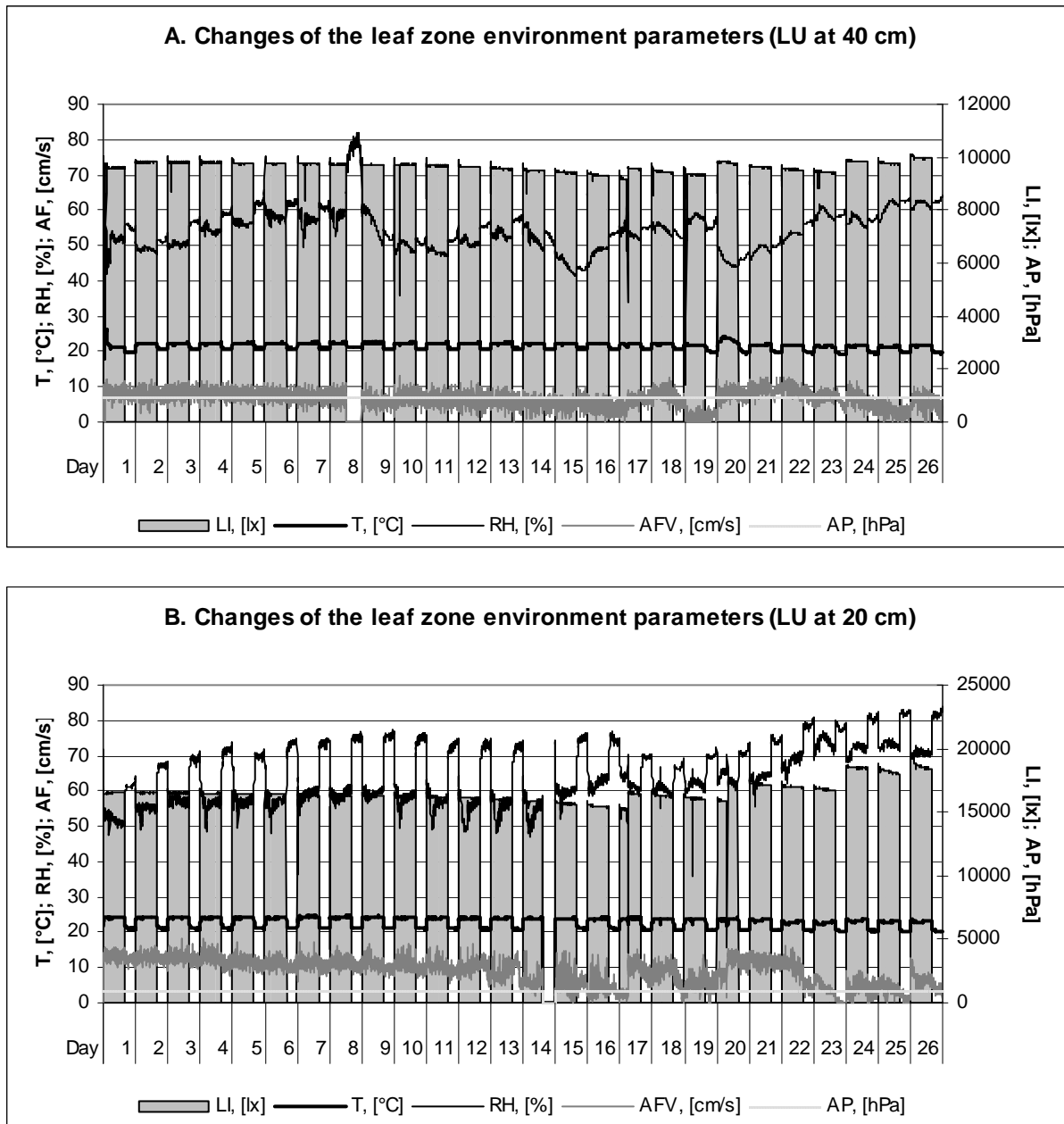

Fig. 3. Dynamics of the environmental parameters' changes measured in the leaf zone during two one-month experiments with plants grown in the SVET SG. (a) Experiment E-5: Light Unit is 40 cm above the Root Module's surface. The volume of the PCh is 55,000 cm³. (b) Experiment E-6: LU is 20 cm above the vegetation surface. The air space in the PCh is reduced two times in volume.

Discussion

As it is expected, the experimental results have shown that the most variable parameters within the PCh are the air flow velocity and the relative air humidity. The latter one has round-the-clock cycle in connection with the photoperiod chosen (16-hour day / 8-hour night). The amplitudes of the RH variations are greater in the second experiment (Fig. 3b). The average values of the RH parameter for a day continuously increased with the growth of the plant biomass during the vegetation process.

It is hard to determine the effect of the permanent ventilation on the RH values. Three concurrent processes must be taken in account: the rate at which the air in the PCh is refreshed, the evaporation from the substrate surface and the transpiration from the plant leaves (RH levels in the laboratory are presumed constant). Furthermore, the last two processes are day/night dependant. A rough idea of the role played by

the ventilation in the support of the RH balance may give us day number 8 of experiment E-5 (Fig. 3a; At that day a power failure has arisen which has affected only the SG supply but not the one of the monitoring system. Similar situation has happened at day number 14 of E-6.)

The AFV parameter greatly depends on the synchronization of the sensors' moving with the growth of the leaf canopy in height so as the sensors to be always at canopy's top. It is the same with the LI parameter.

The temperature within the leaf zone is entirely predictable parameter and depends only on the distance between the T sensor and the Light Unit and on the air conditioning of the environment surrounding the SG.

Conclusion

The plant shoot environment monitoring system proved its proper work and reliability in a couple of plant growth experiments carried out in the SVET SG during the last months. Thus, at present, not only the root environment but the plant shoot one is also monitoring – a necessary step towards the adaptive control concept implementation [5].

Perspectives

It is expected new sensors to be added to the plant shoot environment monitoring system, e.g. for plant chamber gas composition measurements. The number of some of the existing sensors will be increased to ensure measurements not only in the leaf zone of the plant shoot environment but in the all air space of the PCh, i.e. a spatial monitoring.

Regarding the system's software new features will be added concerning: graphical representations of the data; statistics; additional user interface features and options (e.g. printing); event log; relational database storage, etc.

Finally, the two separate plant shoot and plant root environment monitoring systems will be incorporated in one common environmental monitoring system of the SVET-3 SG.

Acknowledgements

This research was supported in part by the Ministry of Education and Science of the Republic of Bulgaria under Contract Number KI-1-01/03.

References:

1. I v a n o v a T. Greenhouse aboard Mir Shows Plants Can Thrive in Space. *21st CENTURY – Science and Technology* (ISSN 0895-682), Vol. 15, No. 2, 2002, pp. 39-47.
2. I v a n o v a T., S. S a p u n o v a, P. K o s t o v, I. D a n d o l o v. First Successful Space Seed-to-Seed Plant Growth Experiment in the SVET-2 Space Greenhouse in 1997. *Aerospace Research in Bulgaria* (ISSN 0861-1432), Vol. 16, 2001, pp. 12-23.
3. I v a n o v a T., S. S a p u n o v a, P. K o s t o v, I. D a n d o l o v. Last Plant Experiments in the "SVET" SG Equipment Onboard the MIR Orbital Station. *Aerospace Research in Bulgaria* (ISSN 0861-1432), Vol. 17, 2003, pp. 108-117.
4. I v a n o v a T., S. S a p u n o v a. Space Greenhouse "SVET" as a Part of a Future Life Support System. *Proceedings of the Fifth European Symposium on Life Sciences Research in Space*, Arcashon, France, 26 Sept. - 1 Oct. 1993, ESA SP-366 (ISBN 92-9092-306-7), 1994, pp. 249-254.
5. K o s t o v P., T. I v a n o v a, I. D a n d o l o v, S. S a p u n o v a, I. I l i e v a. Adaptive Environmental Control for Optimal Results during Plant Microgravity Experiments. *Acta Astronautica* (ISSN 0094-5765), Vol. 51, No. 1, 2002, pp. 213-220.